

HULL BUSTERS APRIL 1999

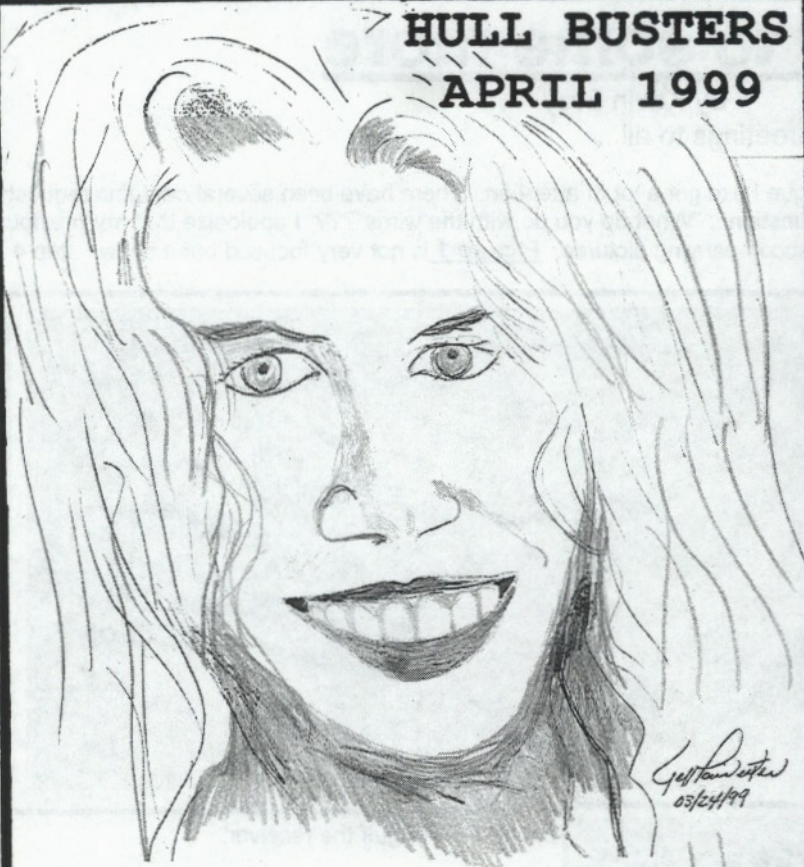

Hi Fluegel:

Don't tell Tom, but I think
Hitler was a snappy dresser too.
Nicole K.

From the President

Not much to tell about anything from the president at this time. No big or wide sweeping changes, no challenges to the rule set, no shakes to the foundations. Spring has sprung, and most combatant's minds turn to getting out on the pond. This is the time of year to try out all of that new construction which occurred over the winter. Spring regionals are just around the corner in many of the corners of the combat world. If you are not near enough to a sponsored regional, then hold your own! It doesn't have to be large for you to have fun and meet other interesting people. In Maryland for many years, our regionals would be between 3-5 boats, but we held them anyway (twice a year, every year!). So get out on the pond and practice, test and tune up the latest and greatest combat ship.

Since the battling season is not too far away, now is the time to send in your IRCWCC membership and NAMBA membership, don't wait 'til the last moment. Nationals (The week of July 11-17) is coming on fast also, so it is time for you to send in your money and information for that event. So mail your \$120 and Frequencies to: Mike Torda, 212 Torda Trace, Waynesville, NC 28786 (1(828) 452-0899)
Marty

Hi,

I'm interested in finding people interested in this hobby in my area that wish to join me in forming an affiliate club of either MWC ink or IRCWCC. Could you put a notice in an upcoming newsletter with my E-mail. Depending on how much interest my group receives determines it's fate. I am a novice (read new) at this hobby, and can't sleep at night since I discovered it!

Tim Blackman
Director of Naval Operation
The Eleventh R/C Combat
Fleet
Albany, N.Y.

Announcing an event

I am announcing an event hosted by the SouthWest Attack Group (SWAG). Saturday, April 17th, ships will converge on the central command headquarters of the Axis fleet, Oklahoma. The event will be at the scene of the horrific destruction of the DKM Lutzow. Since this crime against the Axis, the Lutzow has been raised, refitted, and will not be as easy to defeat.

In light of the fact that the pond we are using "holds the record" for hiding a ship under her waves the longest, I STRONGLY suggest any captain wishing to attend attach a "float" device to their ship. (of course there is the one in Georgia that was never recovered). There are a couple of veterans who feel this is unnecessary for them as they rarely sink and when they do, it is next to shore. "Floats" will not be mandatory. The pond is roughly 2-3 acres. The surrounding 10-15 feet of shore is 1-4 feet in depth. The center of the pond is 5-7 feet in depth.

It is undetermined at this time as to fleet assignments. As CD, I will try and get an idea of participants and if at all reasonable/possible this battle will be Axis/Allied. Anyone wishing to attend please respond back to me... Right now, the participants are as follows:

Bob Eakin (pronounced Akin:-))	USS Washington/USS Iowa
Robert Rucker (pronounced DOA :-))	USS North Carolina/ HMS I-boat
Ted Brogden (a fine modeller/gentleman)	HMS I-boat/HMS QE
Jim Ewer (rusty veteran)	HMS Exeter/HMS I-boat
Scott Bene' (chizzle chest:-))	SMS Vondertann/SMS Chernobyl
Kevin Bray (1-1)	DKM Lutzow/DKM Phoenix

Looks like the Axis has its work cut out for it yet again... That is unless Chris Pierce and

How to some more

By Kevin Bray
Greetings to all...

It seems that my previous article about the balloon technique I use got a lot of attention. There have been several captains request a follow up. The part that seems especially difficult is this question... "What do you do with the wires"??? I apologize that my previous article did not cover this part of the process. Please see accompanying pictures. **Picture 1** is not very focused but it shows step 4 completed. **Picture 2** shows step 6 completed. **Picture 3** shows a fully engulfed receiver and wires that accompany it. Here it is step by step...

Step 1:
Purchase several sized balloons.

Step 2:
take the receiver antenna and lay it across the body of the receiver.

Step 3:
Fill a small balloon with air.

Step 4:
push the end of the receiver that the antenna comes out into the balloon. While doing so, allow the air in the balloon to escape. The

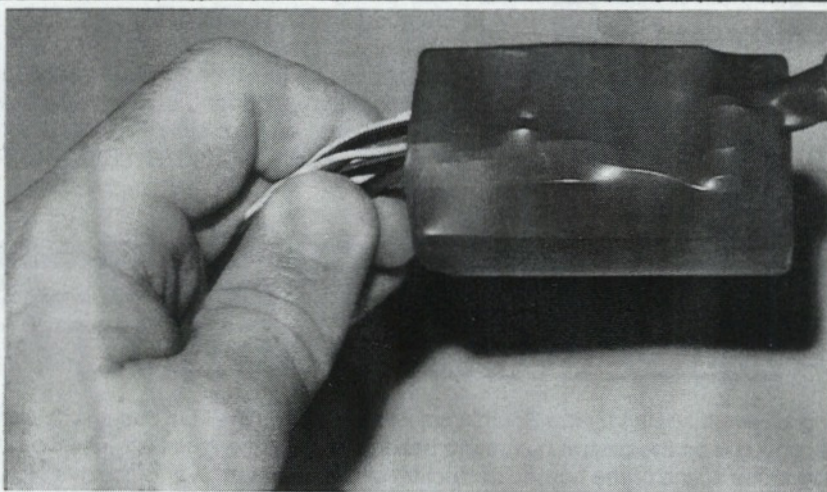
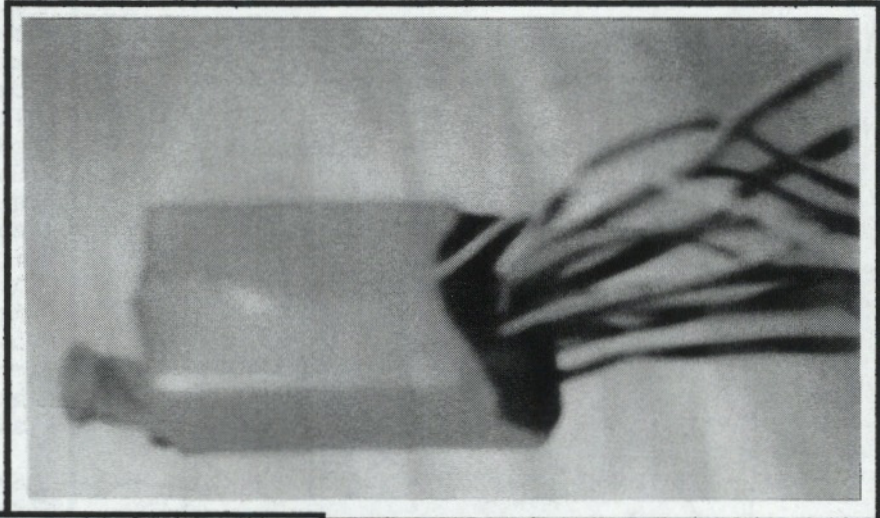

balloon will engulf the receiver.

Step 5:
Organize your servo wires and antenna wire neatly. Lay them against the body of the receiver that has just been covered by the balloon.

Step 6:
Inflate a larger balloon (preferably an elongated one). Take the end of the receiver that has all of the wires attached and press it into the balloon. As you do this, allow the air in the balloon to deflate around the receiver and the wires.

Step 7 (optional)
Repeat step 6 with yet another balloon and engulf the wires. One thing I like about this process is that

if you ever want to get into the receiver again, all you have to do is blow into the balloon and it automatically inflates thus releasing the receiver. The balloon can be reused once corrections to the receiver have been made. I personally do not think getting into the receiver is a common occurrence (unless you are changing out crystals).

Step 8 (optional)
Tie of wires end, use tool dip around balloons...

I used steps 1 through 6 and had excellent results. The first place I heard of this technique was from Robert Rucker. To my knowledge, he does not use it. I have used steps 1-8 on my rudder servo for this years combat. I hope to report back at the end of the season as to the results.

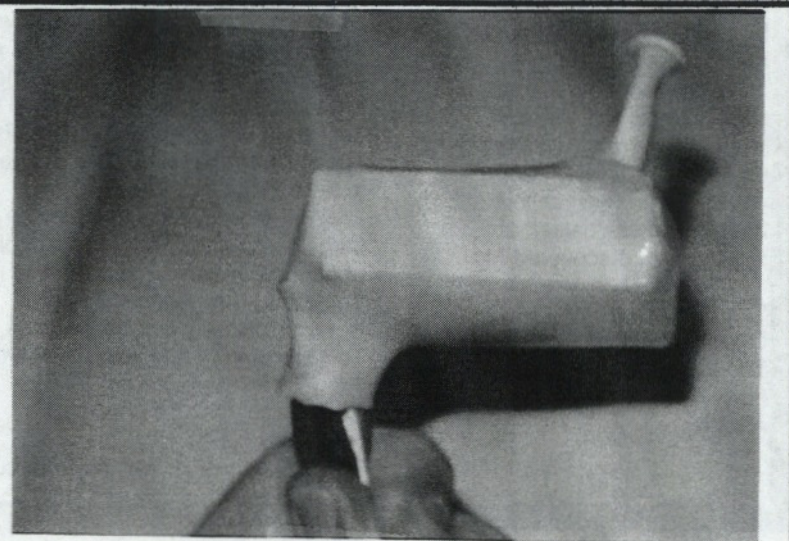

Construction Plan Sets Available

(These plan sets were at one time called 'Legal construction Plan Sets')

It may be necessary to ignore some suggestions on these plan sets to build a model that is legal for the many different 'Combat Clubs' that exist today! These plans are drawn to 144th (1/144) scale.

Page 1 of the 'Two page plan sets' consists of, in most cases, a side view, top view (plan view) and a bow view. Some of the sets also include a stern view.

Page 2 consists of drawings of all the rib (frame) outlines, keel outline, main and subdeck outlines for use in cutting these parts out of wood. The 'One page plan sets' consists of, in most cases, a side view, top view and bow view. Some also show a stern view. There is also a body view, (ribs), either on the plan set or on a separate sheet of paper. All plans were drawn by Jeff Poindexter unless otherwise noted.

(All plans come rolled in a mailing tube with postage, shipping and handling included in the prices shown.)

\$26.00 (Two Page) Cruiser Plan Sets

USS New Orleans class.....	Intermediate
USS Pensacola class.....	Beginner
USS Chester (Houston).....	Intermediate
HMS Exeter.....	Intermediate
IJN Aoba class.....	Advanced
IJN Nachi class.....	Intermediate
DKM Lutzow	Beginner

\$32.00 (Two Page) Cruiser and Battleship Plan Sets

DKM Prinz Eugen class.....	Intermediate
USS Maryland (Drawn by Dan Dees).....	Intermediate

\$22.00 (One Page) Cruiser and Battleship Plan Sets

USS Texas class.....	Intermediate
USS Brooklyn class.....	Beginner
RN Zara class (Italian cruiser).....	Intermediate
Algerie (French cruiser).....	Intermediate

(To make inquiries of these or to ask about plans drawn to order please use same address below.)

Send orders to, and make checks payable to:

Jeff Poindexter
422 E. Bonita
Amarillo, Texas 79108-5222
Phone 806-383-2336

Georgia Regionals

Please announce, in Hullbusters, the MWC Georgia Regionals April 10-11. Bart is site host, I am CD. It is a sanctioned event. Thanks dude.

Your friend,
Ali Zinat

Scale Vs Function

By fluegel

This year at Nats, more people than ever slid rubber or plastic tubes over their cannon barrels to protect them from bee bee damage. I felt it looked terrible, and especially on the best of scale ship! I also felt that it was happening because people were buying their barrels instead of knowing how easy they were to build. Well, I used stainless steel barrels and I had 9 extra, so no need for this old veteran to put those trashy protecting tubes on my scale ship. They're condoms for the guns, kind of pornographic, don't you think? Certainly not to be used in public!

After Nats, but still at Nats, Lief and I had a one on one. I thought I won, but when the holes were counted he had won. I wondered why. There was another time when I had opened up on the starboard bow of an ugly British thing, but when I counted its hits, the starboard bow was not that bad off.?

Stan came to see me this CHRISTmas and he put a piece of typing paper on a box, placed it about 4 feet from the end of his stern guns, and emptied his triple stern guns into this paper. He noted that his beebees hit an area about 2.5 inches in diameter. Most curious. What would my guns do? I tried it, but just with one gun, and it blasted an area about 9" in diameter!

I have been aiming, indeed practicing to hit a area about at the water line and an inch above in the bow. What a fantasy! Even if the guns are aimed at that area, the odds of the beebees hitting there are unlikely. In fact, I could miss their hole ship, either sail over its decks, or splash wasted in the water before reaching the target.

Looking closely at my barrels, I could see tiny dents, beebee dents. When I replaced my dented gun barrels, I got similar results as Stan. I am now thinking about armoring my gun barrels. It's kind of a losing thought, but perhaps the smarter way. I have noticed that I don't have any dents under my barrels where they were covered with a sleeve of K&S brass. Perhaps, this not so noticeable material, is good enough to armor stainless steel barrels.??

What about you? Measure four feet from the end of your barrels. Clothes pin a sheet of paper onto a cardboard box, and shoot a magazine into it. I "threw out" the hole farthest from the center, and then measured the "diameter of death" that each gun dealt out. The smaller the target area, the better my guns will put the beebees on the target. Its a cheap and easy way to improve your ship.

Wade uses Swampworks barrels, and he said "that the more powerful the cannon the more accurate the cannon". He tightened up the barrels, which increases the power, and, it's accuracy.

Next Hull Busters.

Thanks to Jeff for another Hull Busters Logo. I think SEX is the theme for this years logos.?! Thanks also to Pres. Marty, Tim Blackman, Kevin Bray, Ali Zinat, Salini, Curly, Steve Millholand, Chris Perce, Steve Pav, Mike Torda, & Danny Schultz. Without them, there is no Hull Busters!

Dirty is working on a "How too" build a fiberglass hull (as apposed to a wood hull), should be interesting.

Next dead line, May 25th. My e-mail is fluegel7@juno.com I still need 10 to 12 Nats authors. All I need is one page typed, from each Nats authors. I will provide scores and photos. that's not much.

Sneaky Trick #1 by J. Salini

SNEAKY TRICKS

① THE "FOAM SLICK" TRICK

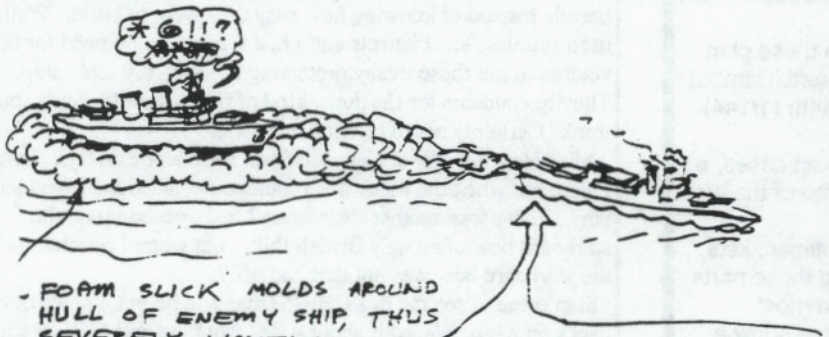

FOAM SLICK MOLDS AROUND HULL OF ENEMY SHIP, THUS SEVERELY LIMITING HIS MANEUVERABILITY.

AEROSOL CAN CONTAINS CHEMICALS WHICH FORM INTO A HARD PLASTIC FOAM 15 SECONDS AFTER SPRAYING. (THIS FOAM IS USED IN THE INSULATION INDUSTRY TO FILL CRACKS IN HOLLOW WALLS).

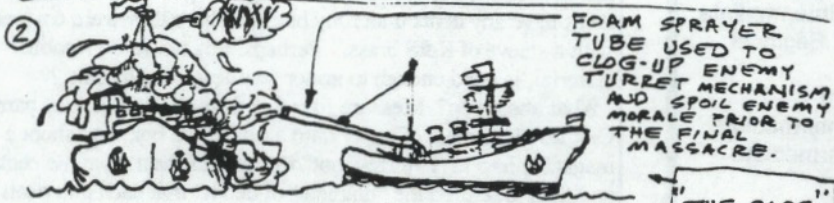
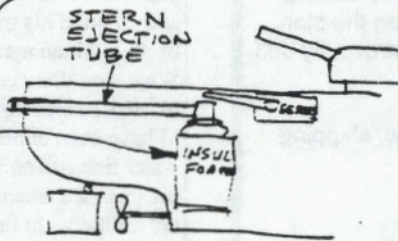

FOAM SPRAYER TUBE USED TO CLOG-UP ENEMY TURRET MECHANISM AND SPOIL ENEMY MORALE PRIOR TO THE FINAL MASSACRE.

③ OPTIONAL SPRAYING MATERIALS:

1. SHAVING CREAM
2. SUPER GLUE
3. CONTACT CEMENT
4. 5-MINUTE EPOXY
5. STP OIL TREATMENT
6. RAW SQUAGE

To Whom It may concern!

I recently found a N.A.M.B.A. 1981 Nationals Program that a speed boat club called 'Muddy Rudders' published for the 1981 N.A.M.B.A. Nationals held here in Amarillo. The 3rd annual RC Warship Combat (later to be known as the IRCWCC) Nationals were also held here that same week at another lake. What is of interest is on page 3 of the program. It is a copy of a waiver that the FEDERAL COMMUNICATIONS COMMISSION in Gettysburg, PA sent to N.A.M.B.A. International in connection with the 1981 Nats here in Amarillo, Texas. The message reads:

TO:
 NAMBA INTERNATIONAL
 WAIVER:
 Rule Section 95.255 (C) is waived for a period of August 01 thru August 08, 1981 to permit the use of frequencies 72,080, 72,240, 72,400 and 75,640 MHZ for the control of model boats. These frequencies under our rules, are reserved for aircraft only operations.
 Waiver approved: Richard H Everett Date: 6/18/81
 Richard H. Everett
 Chief, Licensing Division
 Private Radio Bureau

It seems to me we were discussing this at the Rules Meeting in Hagerstown this last July 1998. I don't remember who it was that wanted this information. If somebody wants a copy of this waiver let me know and I will send it to you. Just send request to Jeff Poindexter, 422 E. Bonita, Amarillo, Texas 79108, or call me at 806 383 2336.

MONEY

By Fluegel

I happily joined the new club, well, happily until I wrote the check for \$15. Why 15? The old club has too much money, and they did it \$6 at a time. What do I get for the \$9 extra dollars? Well, there will be a club "business newsletter". But how about slashing the fee next year, or spend some money on the members, like drinks at lake side.

Charlie "Snoopy's Sea Faring Cousin"

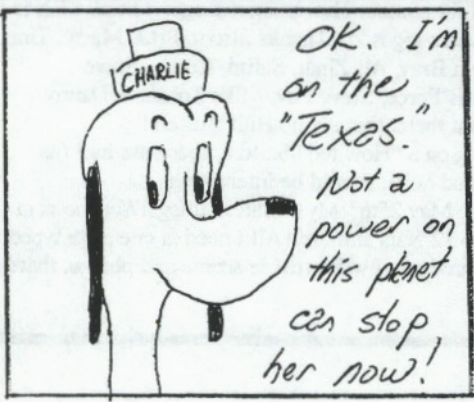

OK. I'm on the "Texas." Not a power on this planet can stop her now!

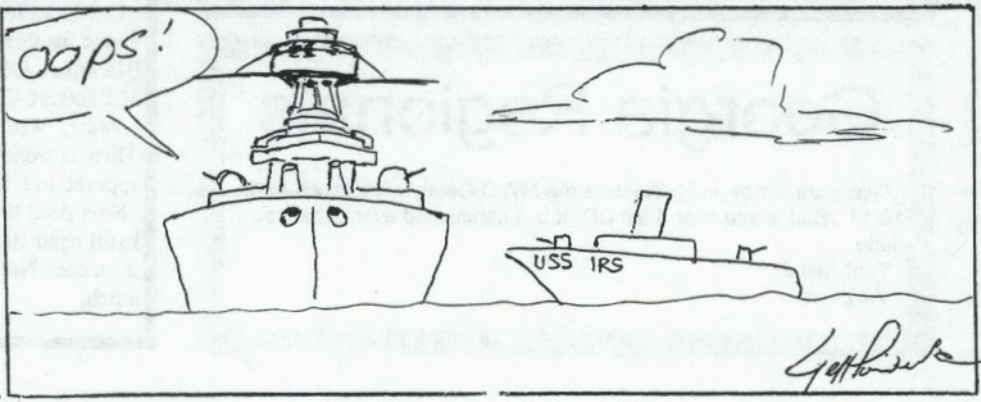

Gettysburg

How I Won the War—on Only 10 Minutes a Day

by Curly Barrett

As I look over my sad excuse for a dockyard, I am dismayed at what I see. The hulls of a half-dozen of Germany's finest ships strewn about like sailboats after a hurricane. The Konig waits for her fourth gun; the Lutzow is only half-planked; the Seydlitz is without a radio; the Scharnhorst is nearly ready for it's fiberglass



Sneaky Trick #2 by J. Salini

"THE WATER LINE CANNON TRICK":

CANNON CONSTRUCTION

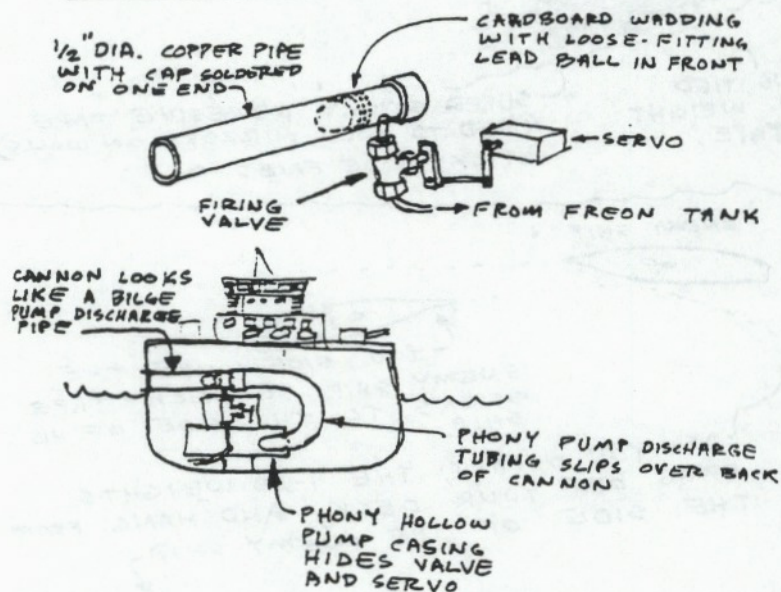

OPERATION:



bottom; the Steir is ready for its motor, the Posen is merely a showy display of superstructure over a hull that is as empty as the Tinman's chest; the mighty Bismarck, a Swampworks kit that I received as a Christmas present from my wife over a year ago, stands majestically atop a pile of sawdust left over from the Carter Administration.

The piles of tools and supplies are precariously stacked in towering piles that would put Fibber McGee and Molly to shame. The two chairs in the dockyard have a board between the top of the backs of the chairs to provide additional work space. The bottle of jet glue is somewhere...

Yet this is just standard operating procedure for me. I have too much going on—three little boys, graduate school homework, a few hobbies, freelance work—and very little time. So when I do work on the boats, I don't waste time by cleaning up!

And every once in awhile, I notice that I am ignoring the boats entirely. When that happens, I fall back on the "magnificent obsession" plan that helped me earn the 1986 Rookie-of-the-Year award. That plan is simple and easy, but gets the job done.

First, admit you have too much going on in your life...don't worry and fret. Second, try to spend just 10 minutes a day in your dockyard, no more...no less. That ten minutes is amazing! I can put most of my tools away in just 10 minutes. I can add a sheet of balsa to a hull in 10 minutes. I can put on a waterline in just 10 minutes. I can even find the glue bottle in 10 minutes.

Best of all, I can lose track of time in 10 minutes...and that's how I do it. Just 10 minutes at a time. Make the commitment to put in those 10 minutes every day. Your fleet is counting on you!

MO Notes:

by Steve Milholland

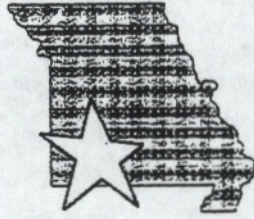

Hi Captains. It is time to prepare for the 1999 Ozarks Spring BB Fest, to be held here in Springfield MO on the weekend of May 29 & 30, 1999.

It looks like this event could have even more contestants than the 27 we had last year at the Spring event. All of our die-hard regulars will be here. There will also be quite a few new rookies attending their first battle here too. Let's make them all feel welcome (Attention Rookies: This means not sinking you until the Second Sortie on Saturday morning).

CONTEST PARTICULARS.....

SANCTIONING. This is a sanctioned event. All participants MUST have current Model Warship Combat, Inc. (MWC) and NAMBA membership. Cards will be checked.

ENTRY FEE. \$12.00 per person in advance. Entries must be postmarked before May 12th and include your CHANNEL NUMBER, not frequency. Late entries and at lakeside will be \$18.00 per person. We need paid entries ASAP so that we can cover expenses, work out any frequency conflicts and notify the concerned Captains. No-shows who send advance entry fees will be refunded 75% after the event.

Please Mail entries written on a piece of paper to: Steve Milholland, 1810 Farm Rd. 197 North, Springfield, MO 65802.

**** A note about frequencies ****

Channels 00-09 in the 50 & 53 mhz bands are reserved for use only by persons holding the appropriate FCC Amateur License. A valid FCC Amateur license must be shown by any Captain operating a licensable frequency at this event.

For your combat and refreshment needs, the hosts will be providing Co2, soft drinks and ice at lakeside.

ACCOMODATIONS. BB Fest HQ is Motel 6 North, at 3114 N. Kentwood, Springfield, Missouri. The motel is just off Exit 80 on the North side of I-44 (NOTE: Don't go to Motel 6 South, which is also visible from I-44 and just across it from Motel 6 North), PH: (417) 833-0880 for reservations. I advise you to make your reservations NOW.

Springfield and the surrounding region is a major tourist area (we are only 35 miles from that gonzo holiday mecca, Branson), plus, this being Memorial Day weekend, motel rooms will be not just difficult to find but totally unavailable for the "last minute" traveler.

Don't end up like some of the guys at last years event who had to stay at other motels or ended up carting all their gear up to the third floor.

Make motel reservations NOW, then you can cancel later if it turns out you can't make it after all.

THE LAKE. Ritter Springs Park. Just Northwest of the city out in the country. To find it, just follow the convoy from the Motel 6 on Saturday morning.

Shade has always been limited in the pit area here and table space is completely non-existent. Bring your own work table, chairs, and shade source if you think you need it. Don't plan to work out of a mini-van or pickup tailgate. The vehicles will have to be parked some distance from the pit area and all ships and battlers must set up in the marked pit.

Here's looking forward to a Great Battle.

See ya' there,

Steve SWAMPY Milholland

Ph: (417) 831-2309 e-mail: swampy@ncsi.net

Sneaky Trick #3 by J. Salini

"THE RE-BALLASTING TRICK"

1-LB LEAD WEIGHTS LAID ON DECK

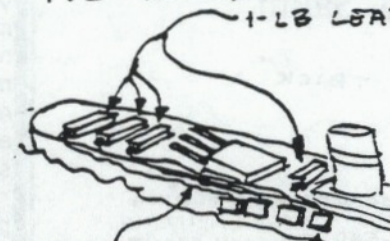

STRING TIED FROM WEIGHT TO TAPE.

SUPER STICKY ADHESIVE TAPE (USED TO HOLD MIRRORS ON WALLS) STICKY SIDE FACES OUT.

ENEMY SHIP

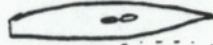

YOU SIDE-SWIPE THE ENEMY SHIP SO STICKY TAPE STICKS TO THE SIDE OF HIS SHIP.

AS YOU DEPART, THE 1-LB WEIGHTS DRAG OFF YOUR DECK, AND HANG FROM THE SIDE OF THE ENEMY SHIP.

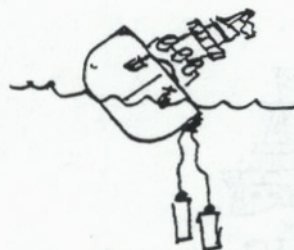

YOU CAN GET SOME NICE HULL-SHOTS WHEN THE ENEMY IS BALLASTED LIKE THIS.

Antenna

By Fluegel

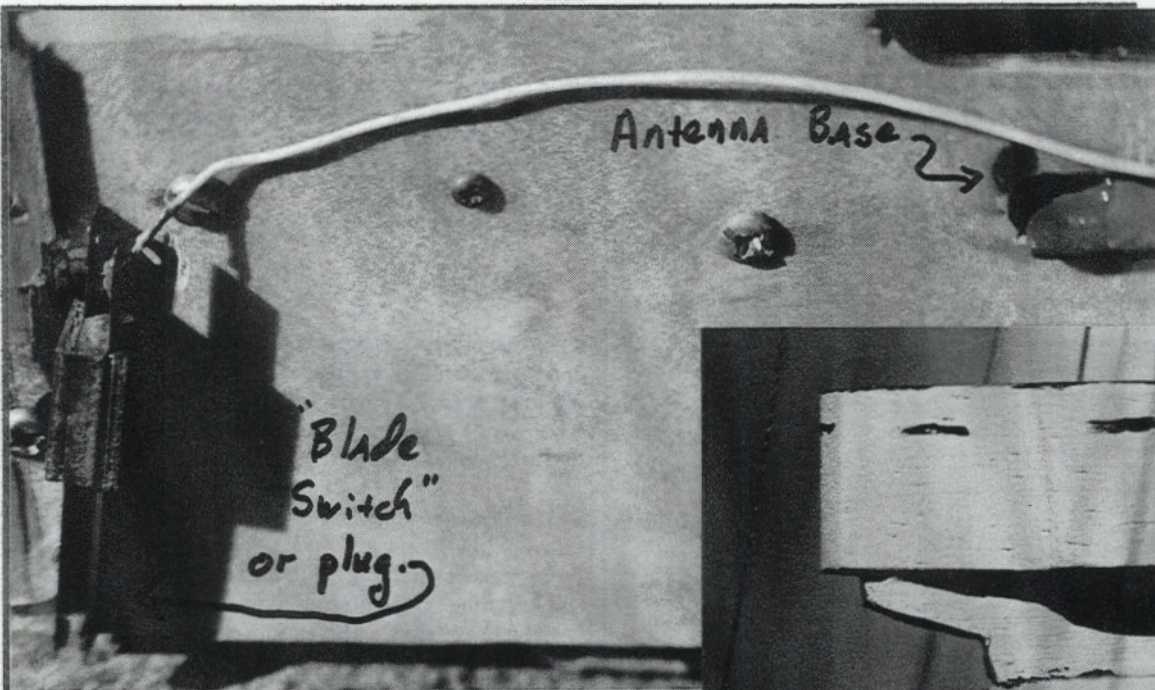

Last fall, at a Houston Battle a couple of rookies showed up with Lutzows. Interestingly, they both had tall (18") neon bright antennas. They whipped the air every time the ships turned. I think these antenna are for race cars?. Since then, one, maybe both have replaced their receiver antennas with "helicopter" receiver antennas (\$9).

I encourage the use of these antenna. I think they may be the most common antenna in the hobby...?, and they should be. They work very well, and are easily hidden in your ships superstructure, making you model look more like a ship than a nascar..

The top photo is of the bottom of my superstructure deck. The "blade switch" is connected to the base of the antenna by a wire. The blade switch is used to "rub" against a screw, shown in the bottom photograph. This set up replaced a plug that was on the wire that connected the receiver to the antenna. It was a hassle to

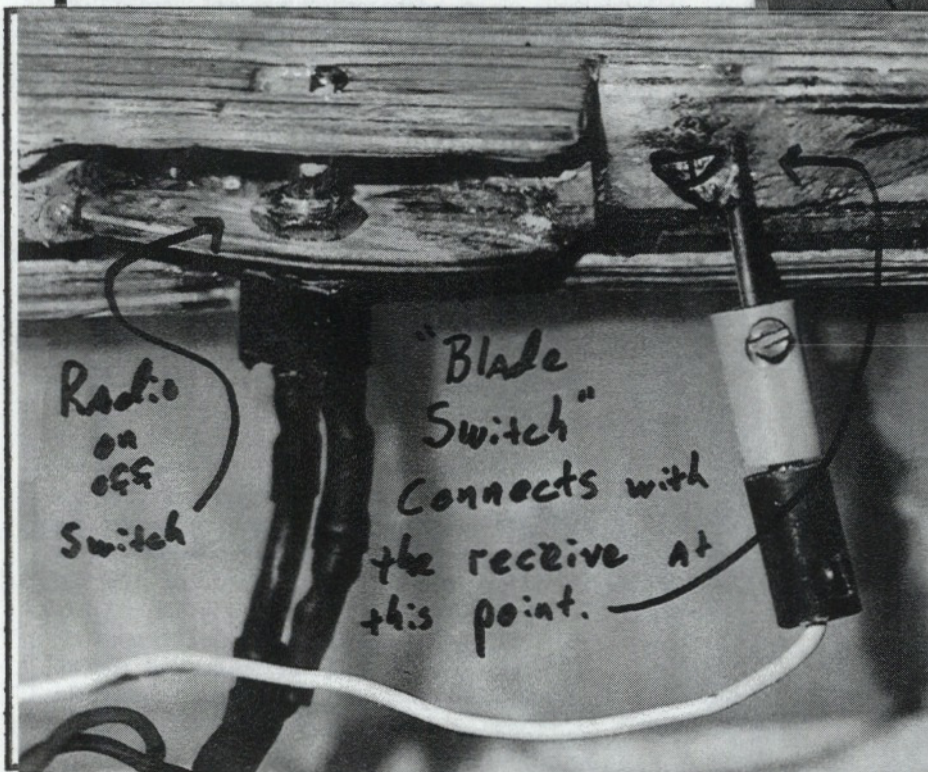
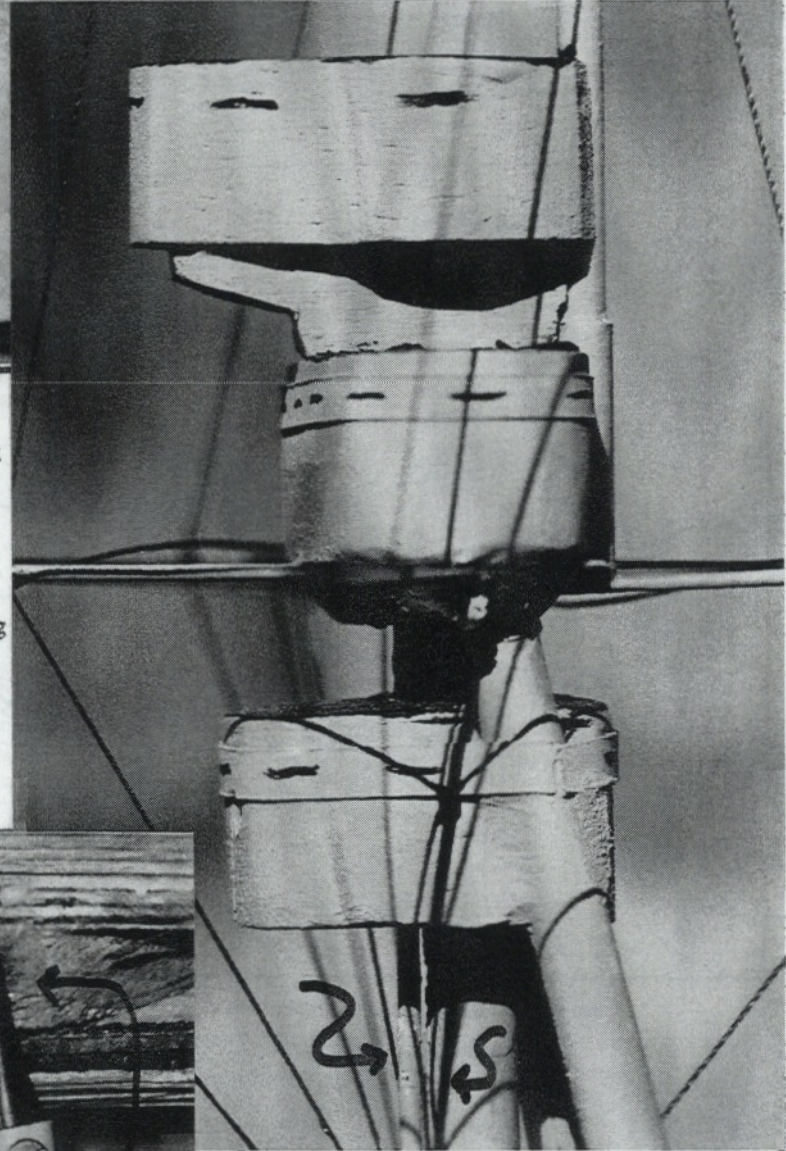

always be plugging it in. That screw is the second part of the new antenna "plug". In turn, the screw is connected to a wire that runs into the water tight box, to the receiver. The plug shown in the photo is used to disconnect the wire from the screw so I can take out the water tight box.

The middle photo was taken to show the "hidden antenna" in the bridge area, can you see the antenna? Look at the middle bottom of the photo to see the antenna.

Sneaky Trick #4 by J. Salini

THE ALLIGATOR SHIP TRICK

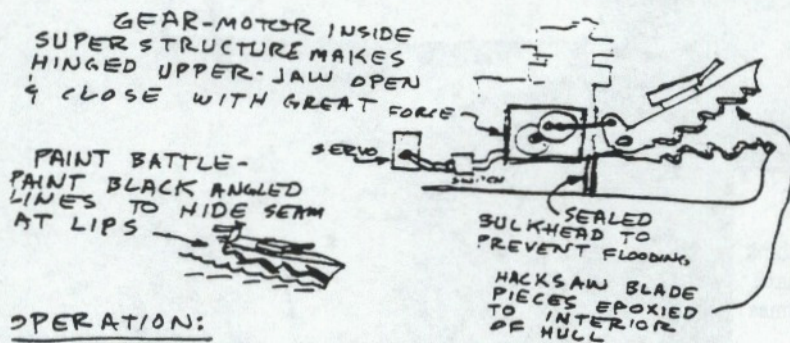
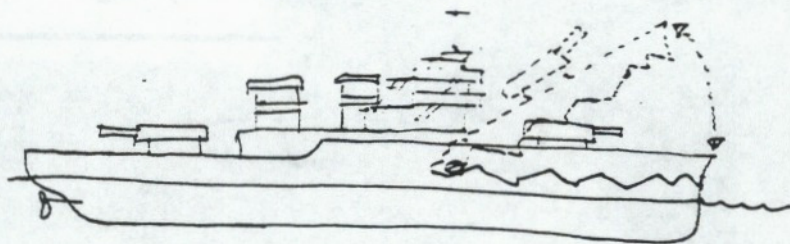

OPERATION:

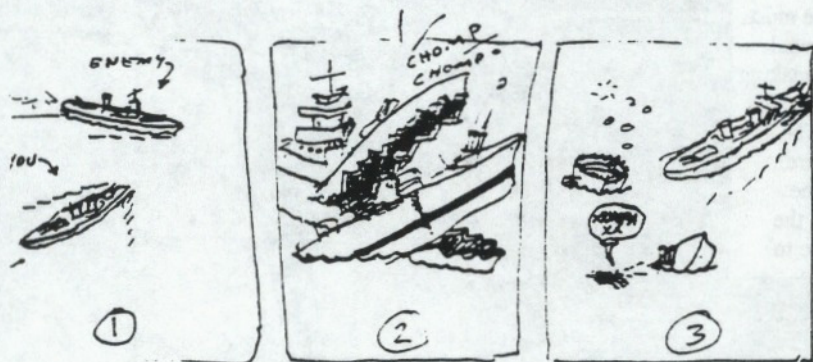

Can you find the sunken American ship in the weeds?



Battle Report: Houston

Gentlemen,

Yesterday, Larry was most impressive... Being on the opposite side of his new ship, I can attest to the battle effectiveness of it. Finding a target that moves like a rabbit and then getting a "hit" on it is nothing a "rookie" like me should attempt.

Of the 6 ships in attendance, 4 were heavy cruisers (3 Lutzows, 1 Houston class target). The other was that of the furior himself, Heir Fluegel in the baden. There were 5 sorties during this sometimes rainy day. I will not get into what happened each sortie but the outcome was a resounding Axis win. Skyrucker was still plagued by the winds of misfortune. He experienced multiple setbacks including having to change out one of his guns. I recall the USS Chicago sinking twice. I believe that in spite of his problems, Skyrucker enjoyed the day and the battling atmosphere. WadeKoehn from Louisiana and his Lutzow also seemed to be spending a lot of time getting wet. The other 2 Lutzow's did a lot of parading around (I being one of them). The offensive capability of these ships was in question. Neither of the two sank or suffered much damage and they both seemed to have problems with both gun tweaking and ranging them for effectiveness. To accent this, the third sortie was a challenge from my fellow Rookie and host of the event... Paul Block. I would suggest that any allied captains remember his name because even though he is yet a rookie, he showed lots of real talent in both the building and battling of his ship. In this sortie, we proved the ineffectiveness of our offensive capabilities by firing all 125 rounds from our guns and neither of us scoring a hull penetrating hit. There was some superstructure damage but as Fluegel pointed out, My ship can only get better looking! :-)

After driving from Dallas to Houston with Fluegel, I have decided to concentrate much of my off season time this winter getting my ship more scale. A rookie note here: Any rookie reading this would be wise to concentrate an equal amount of time into making your ship battle worthy and making it look good. Many of the veterans out there feel that some of the newcomers to this hobby are interested in only the battling and the glory of sinking ones opponent. I would agree with this statement because most of my time I have spent trying to insure my ships survivability and I have focused less on detailing out my super structure. This allowed me to compete in the fall Springfield battle and while I believe that most if not all of the captains were glad to see my ship there, it was not something that they would want to take a picture of and keep. Enough said...

Back to Larry's ship... In what I remember was the fourth sortje, Larry's ship went dead in the water. He called 2 minutes and both Fluegel and I began to position ourselves for the kill. Once Larry realize that his ship did not have much chance of surviving, he declared it sunk. Fluegel and I attempted to push it into shore. This is where my greatest shame occured. You see... While Fluegel is a greatly experience captain, I still need much more stick time. As I was trying to position my ship to lightly push Larry's ship, I came in quite a bit to fast and rammed Larry's Gearing. The angle of our ships did not help me to judge the speed of our ships well and after pushing his ship for about 2 feet sideways, it took on water and was going down. It stayed afloat for some time and Larry was running around considering how he could change into some shorts and get into the water. This is when Heir Fleugel told me that I should get into the water and get Larry's ship. Of course, I was already moving that way. In chest deep water, Larry's Gearing slipped under the water just as I was getting to her. I quickly found her and brought her ashore. This was the second time I have gone into the water to retrieve another captains ship... Anyway, I still feel badly how this whole thing came about. Larry was very nice about it and he is an excellent gentleman.

The rest of our time together was spent at a Chilis restraunt pouring over the days events... The people that I meet in this hobby have proven to be excellent hosts and people rich in character. I look foward to my next opportunity to compete!

Kevin

Kevin and Larry.



Anal, and I know

it.
Fluegel

I have accidentally adjusted by radio's trim tabs. This has caused me to vent my CO2, and when battle began, Fluegel had no CO2. I have also seen others do this, Bart comes to mind. Well, I ground off the "bump" on my tabs, and cut a slice into the plastic. I use my finger nail to adjust the trim.

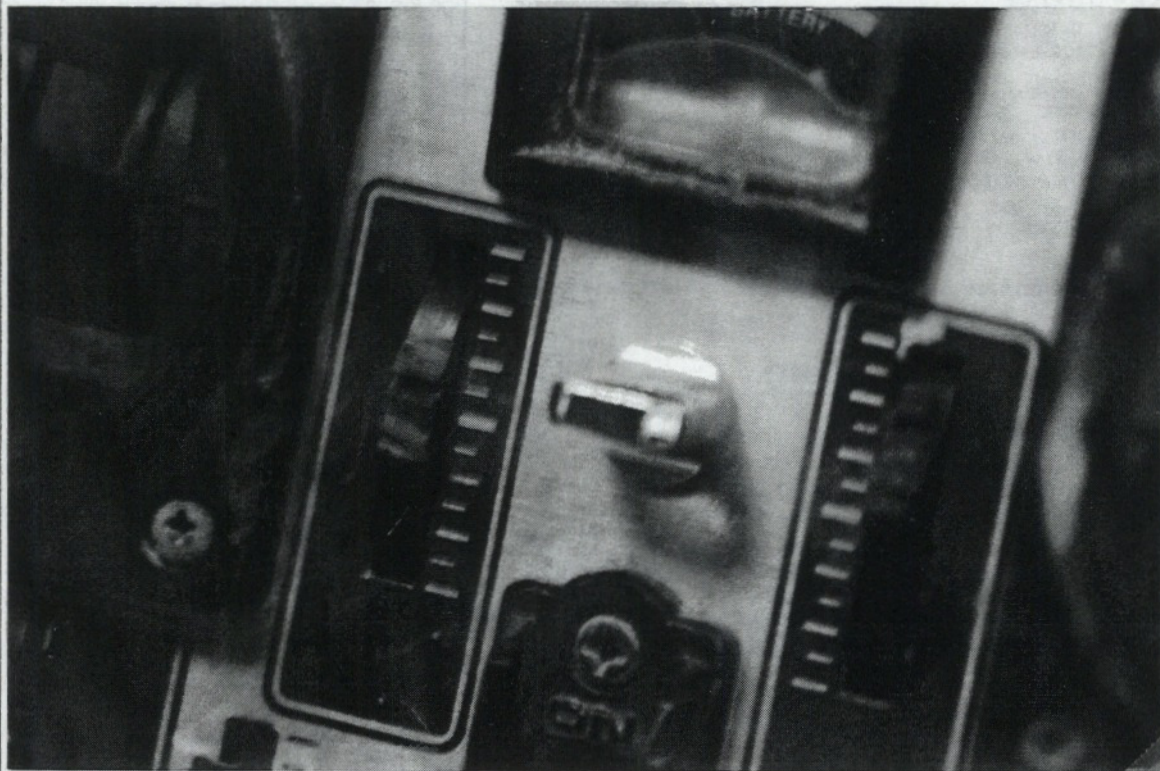

Sneaky Trick #5 by J. Salini

THE "BATTERY-DRAIN" TRICK

SLIP ONE OF THESE BATTERIES INTO THE ENEMY'S TOOL KIT:

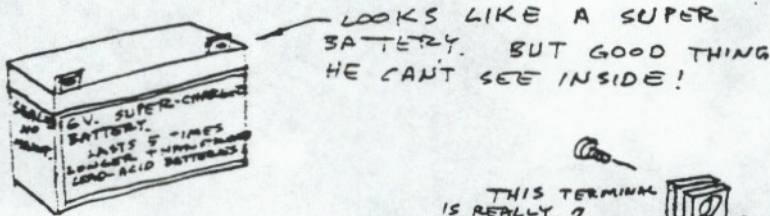

LOOKS LIKE A SUPER BATTERY. BUT GOOD THING HE CAN'T SEE INSIDE!

THIS TERMINAL IS REALLY 2 TERMINALS WHICH ARE ISOLATED WHEN A CONNECTOR BOLT IS TIGHTENED IN, THEY MAKE CONTACT LIKE A SWITCH.

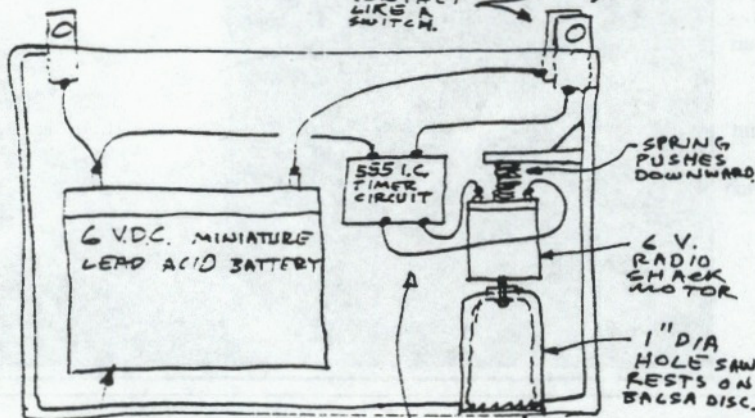

MINIATURE BATTERY INSIDE PROVIDES ORDINARY 6V. POWER TO OUTER TERMINALS.

ELECTRONIC TIMER TURNS ON HOLE-SAW MOTOR 5-MIN. AFTER BATTERY IS CONNECTED IN SHIP. HOLE SAW QUICKLY CUTS THROUGH BALSAM DISC, THEN PROCEEDS TO DRILL A 1" HOLE THROUGH THE BOTTOM OF THE SHIP.

1" DIA HOLE SAW RESTS ON BALSAM DISC.
1/8" BALSAM DISC GLUED IN HOLE AND PAINTED TO LOOK LIKE BOTTOM BATTERY SURFACE

SPRING PUSHES DOWNWARD.

-Hey folks-- The Pav

Just a note to tell you all about the East Coast Hobby show held this past weekend, March 13 and 14, in Fort Washington Pa.

The show allowed IR/CWCC a table which volunteers from MAG manned to share our hobby with other R/C and building types.

On Saturday, Marty "the Legend" Hayes sounded 20 years younger sharing building tips, rules and club history with such enthusiasm you would have thought he was selling Amway. Also present on Saturday were the brain stormer of this outreach, Larry Ricci and his son David and hobby sophmores Matt and Cameron Maury.

On Sunday a new team took to the floor made up of myself and my second favorite roommate in the world, Tom "I never seen him asleep at night" Tanner. Tom braved the trip from D.C. in spite of weather forecasts of a winter storm and I am indebted to him for being there. Thanks Tom!!!!

Our table was a simple display of boats in from just formed fiberglass hulls to completed ready to battle ships. We also had on hand a beautiful cannon display ("courtesy of Frank Pittelli") to explain cannon operation, videos of '90, '93, '97, and '98 Nats running constantly, newspaper, magazine articles, issues of the worlds greatest newsletter Hullbusters, Swampy catalogues, and fliers about upcoming events and internet links through MAG, NEDF, and NABS sites.

Both days we were bombarded with people excited to hear about what we do and how we do it. Questions ranged from "How do you retrieve a boat when it's sunk?", to "I've got a kit, here is where I'm at, how do I go to here?" Comments were heard like, "you're sick! sinking your toys like that!!!" and "Seig Heil!!!, I want to build a Bismark and rule the world!!!" (For more info on that guy, please ask Marty)

I was great fun and hopefully we will find more hobby brothers out there to join us on the water!!! Take Care and God Bless!
Pav

Axis Admiral Selected By, Admiral Chris

With the deadline past, and votes too close to call, and in some cases, too difficult to tell if they should count or not, a conference was called among the front runners and other Axis leadership. After discussion, the two candidates decided that rather than split the party, they would prefer to throw their support behind a third candidate, whom it was well know would appeal to all, with his charm, wit, and proven combat leadership. That candidate, and our new Admiral (again) is David Haynes. He will be dutifully served by two vice Admirals, Wade Koehn and Chris Pearce. Together, they will lead the Axis fleet into a new era of enlightened leadership.

Vide Admiral Chris Pearce offered this message, "I would like to thank David for offering us his valued leadership, and offer him my utmost in support for the coming Nats. I look forward to serving under him and to this opportunity to serve the Axis fleet, and the hobby."

Move into your FREE Internet apartment!
<http://www.myspaceonline.com>

News from

SWAMPWORKS

Hey guys,

Hi guys. It's been a while since SWAMPY's last entry to HB. It's been a busy winter. I've developed a few new products as well as producing a completely new web site and online catalog (if you've not seen it yet, give it a look. URL below).

NEW STUFF.....

Swampy's workshop is now making resin molded turrets available as an "add on" for those of you who have some of our warships kits. These same turrets are also now being supplied as "standard issue" in our kits in place of the old vacuum molded turrets we used to supply.

Main turrets are now currently available for the following kits, ships and hulls.

USS North Carolina, South Dakota, & Iowa classes

USS Houston (Northampton), Indianapolis

USS Brooklyn

DKM Bismarck

DKM Lutzow, Scharnhorst

HMS Invincible

SMS Moltke, Derfflinger, Von der Tann, Seydlitz

We also have 5 inch DP secondary turrets, US battleship main rangefinders, and Mk37 secondary rangefinders available in resin. SWAMPWORKS also now makes a line of seven different styles of resin molded rudders ranging in size from 1-7/8 sq. in. to 3.5 sq. in. These come with a 1/8th in. dia. brass shaft molded in. These are now supplied as standard in all of our warship kits. These rudders all have a smooth "airfoil" cross section and are tough as nails.

Since November, 1/144 scale hulls for IJN Nagato-Mutsu and SMS Baden-Bayern have also been available for those who wish to build them. We are particularly proud of the beautiful new Nagato-Mutsu hulls. The master plug for this ship was made for us by "Dirty Dave" Haynes, a long time builder of many beautiful Japanese ships.

To see some nice photos of some of these new items please check out our new web site's on-line catalog. Prices can also be found there or you can call or e-mail us for them.

COMING THIS YEAR.....

Currently we have master plugs completed and ready to fabricate molds for the following ships: USS Atlanta, USS Arizona-Pennsylvania, USS South Carolina-Michigan, USS Tennessee-California, and IJN Kongo-Kirishima-Hei. As soon as a few free days present themselves, I plan to start on a couple of these. I hope to have at least a couple of them available for "Show & Tell" by Spring Regionals time.

Masters for main turrets for the SMS Baden, USS Arizona-Penn, IJN Nagato, and USS Tenn-California are also just about finished. Once these are delivered to me, I should be able to get the molds made fairly quickly. I'll make an announcement here and on the internet E-mail group as soon as they are available.

Regards to all.....

Steve "SWAMPY" Milholland

Phone: (417) 831-2309

E-mail: swampy@ncsi.net

Web site & online catalog: www.swampworks.com

NATS TO YOU

The week of July 11-17 is fast approaching. And the IRC/WCC North Carolina Nationals are Going to be great. Steve Milholland is once again going to be the allied Admiral, bringing with him many years of proven combat strategy. I'm going to be the Axis admiral. I am confident that with the new improved Axis fleet and some new tactics that we will be victorious. I also am the only one who knows where in the lake I have hidden those huge electro-magnets, "when the allies sink, they sink QUICK!"

We have reserved rooms in the Sunnyside Lodge which are very basic hotel rooms sleeping 3 or 4. These rooms are not of the highest quality, no TV etc. but are dirt cheap; Single \$26, Double \$16, Triple \$13. Hotel reservations for Nats '99 can be made through the Lake Junaluska Assembly's reservations office 1(800)222-4930.

I am also going to be hosting the Second annual S.E. Mountain Battle April 24-25 at the Nats lake site. Cost is \$15.00 and CO2 will be provided.

**1999 IRCWCC Nationals
Registration Form**

Captians Name- _____
Street- _____
City+ZIP- _____
Phone- _____

Warship 1 Class___ Channel+Freq _____
Name- _____

Warship 2 Class___ Channel+Freq _____
Name- _____

Warship 3 Class___ Channel+Freq _____
Name- _____

Convoy 1 Class___ Channel+Freq _____
Name- _____

Fee: \$110.00 (Before Feb 28.)

\$120.00 (Before May 31.)

\$135.00 (After May 31.)

Mail to:

Mike Torda

212 Torda Trace

Waynesville, NC 28786

1(828)452-0899

IRCWCC

Fluegel, treasure

Some of you sent your dues in last December. Well, we just got our rules packet put together. I mailed them late in March. If you have not received your rules packet, contact me (fluegel7@juno.com).

To join the club, send \$6. To subscribe to Hull Busters, send \$9. To do both, send \$15 to Fluegel at 917 Hudson, Garland Tx 75043.

Sneaky Trick #6 by J. Salini

"THE SHIPWRECK-MONSTER TRICK"

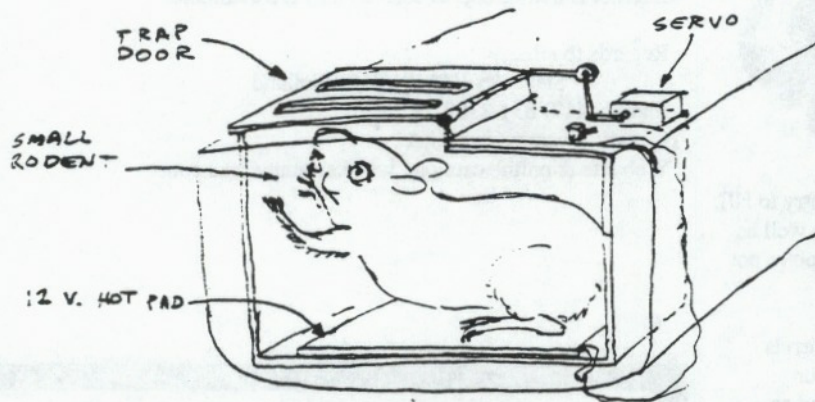

BUILD A CAGE IN YOUR SHIP TO HOLD A SMALL RODENT SUCH AS A GUINEA PIG, RABBIT, ETC. (THE BIGGER-THE BETTER) CONNECT THE SERVO TO TURN ON A 12-VOLT HEATING PAD ON THE CAGE BOTTOM, AND OPEN THE TRAP DOOR AT THE SAME TIME. — THIS WILL CAUSE THE RODENT TO JUMP OUT OF THE CAGE WHEN THE SERVO IS ACTIVATED.

ACTIVATE THE SERVO AFTER COMING ALONGSIDE THE ENEMY SHIP. THE RODENT WILL JUMP OUT ON THE ENEMY SHIP, SCRAMBLING AROUND TO FIND A STABLE SPOT. SINCE THE SHIP IS NOT STABLE WITH HIM ON TOP, HE WILL CONTINUE TO CRAWL AROUND UNTIL ALL THE DECK FITTINGS ARE DESTROYED OR UNTIL THE SHIP CAPSIZES.



Great Idea

by Danny Schultz

Using a old ironing board for your boat table.

1. they are cheap. You can find them at yard sales for just a couple bucks
2. they are easy to store .. folds flat
3. they adjust to differant hieghts
4. they can hold any ship in the hobby
5. you can work on both sides without other things being in the way

Now I'm talking the metal ones not the wooden ones. You need to either run extra pipe at the feet to give it some stableness or run spikes the ground
But otherwise it is very good. So you can put all our extra gear on the table . And you can have a "L" type work station.

North Carlaina Nats

fluegel

This one will be different. I studied a book of available summer houses/apartments/condos last night for one hour. We may be a group of 4 up to 8 depending on which house we select. "Hotel / Motel" fellowship has been a BIG part of Nats fun. What will "summer house" fellowship be like?

To keep it more fun, we (Kevin Bray, Tom Tanner, Pav, and myself +?) are mixing up the residence, some experience, other rookies. Some East coast, other from mid America. Why, I will even be sharing a room with an Allie! It's not true, they do use deodorant.....don't they?

Fluegel
917 Hudson
Garland Tx
75043

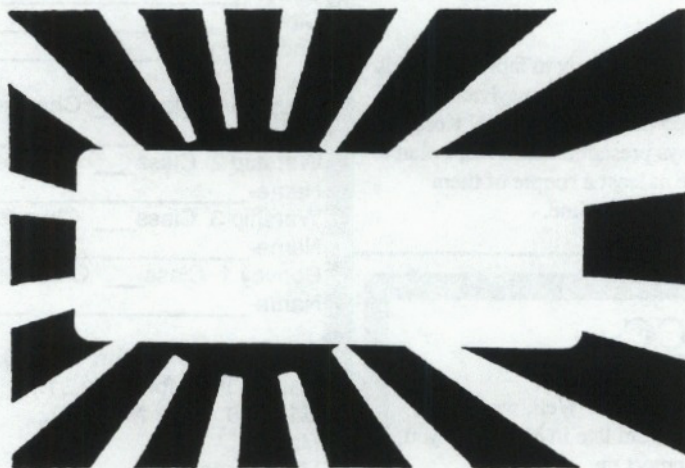

The ensign of the Imperial Japanese Navy